

# **UNI-VAC**

## **Model: 400 Series**

- **Cost Effective 300 CFM Rotary Piston Vacuum Pump**
- **Performance And Durability At A Reduced Cost**
  - **All Spare Parts In Stock**
- **Inlet Traps, Exhaust Filters, Fluids Available**
  - **Two Year Warranty**

### **APPLICATIONS:**

- **Vacuum Heat Treating**
- **Vacuum Brazing**
- **Vacuum Coating**
- **Transformer Drying**
- **Degasification Systems**
- **Shelf Drying**
- **Vacuum Casting**
- **E-Beam Welding**

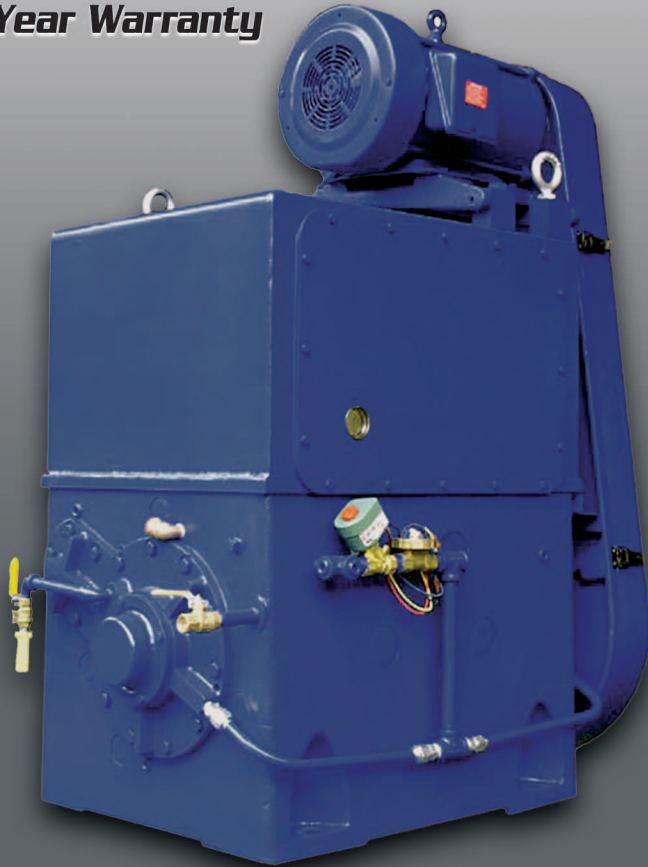

**UNITED VACUUM**

NEW JERSEY - USA • TEL: 888-742-7202  
[www.unitedvacuum.com](http://www.unitedvacuum.com)

# Model: 400 Series

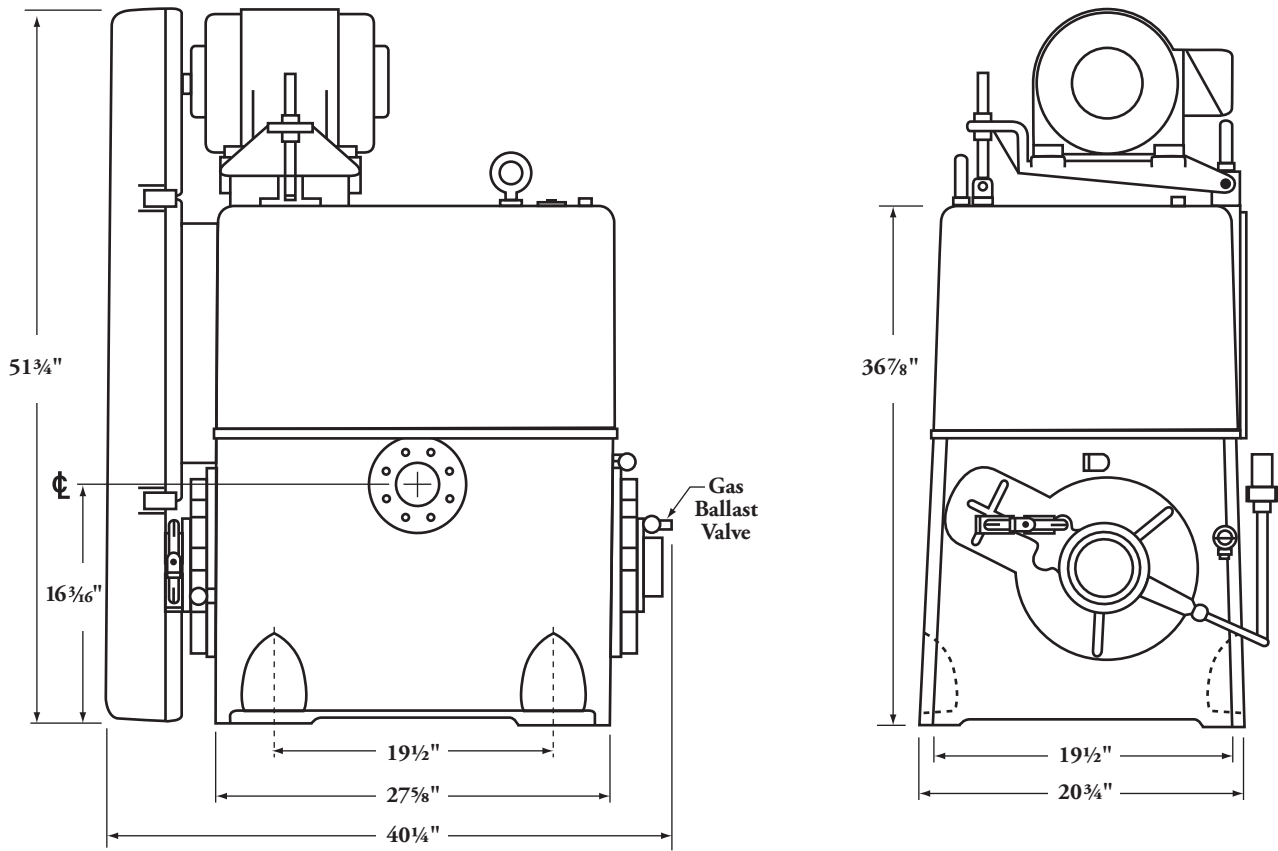

## 400 Series Specifications

Free Air Displacement: .....300 CFM  
 Vacuum Stages: .....One  
 Ultimate Pressure: .....0.001 Torr  
 Motor Rating: .....10 HP 208/230/460V  
 Pump Speed: .....490 RPM  
 Oil Capacity: .....12 Gals.  
 Weight: .....1750 lbs.  
 Inlet (ASA Flange): .....4"  
 Outlet (Female NPT): .....3"  
 Max Cooling Water 65° F: ....2 GPM

